

1 2 3 4 5 6 7 8

A

A

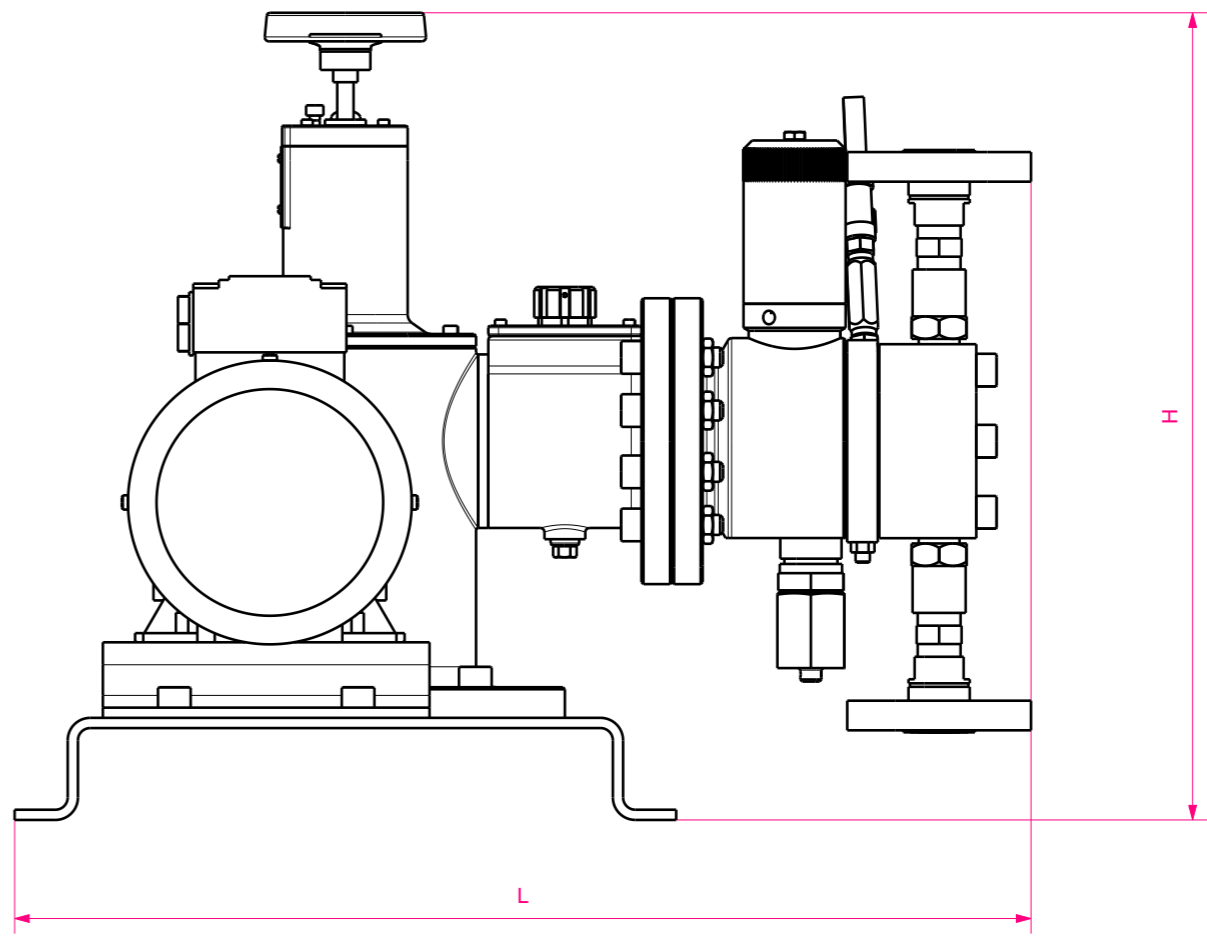
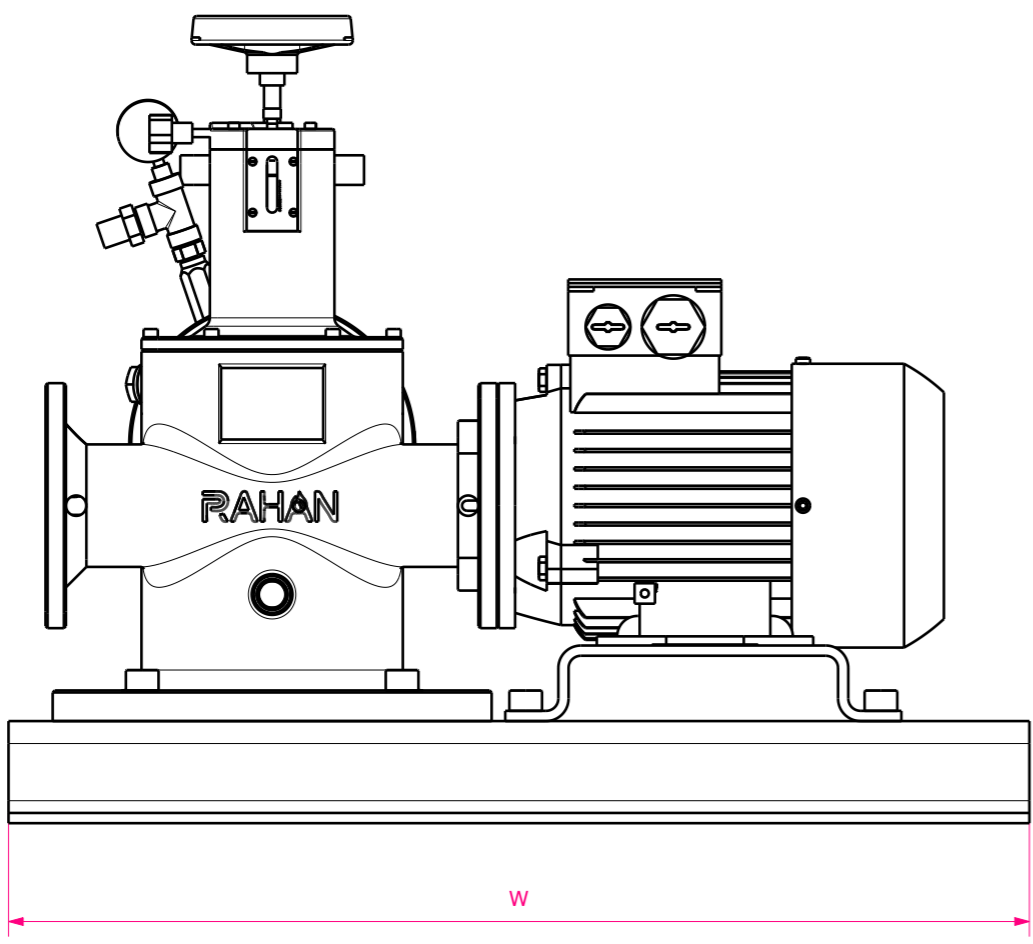

B

B

C

C

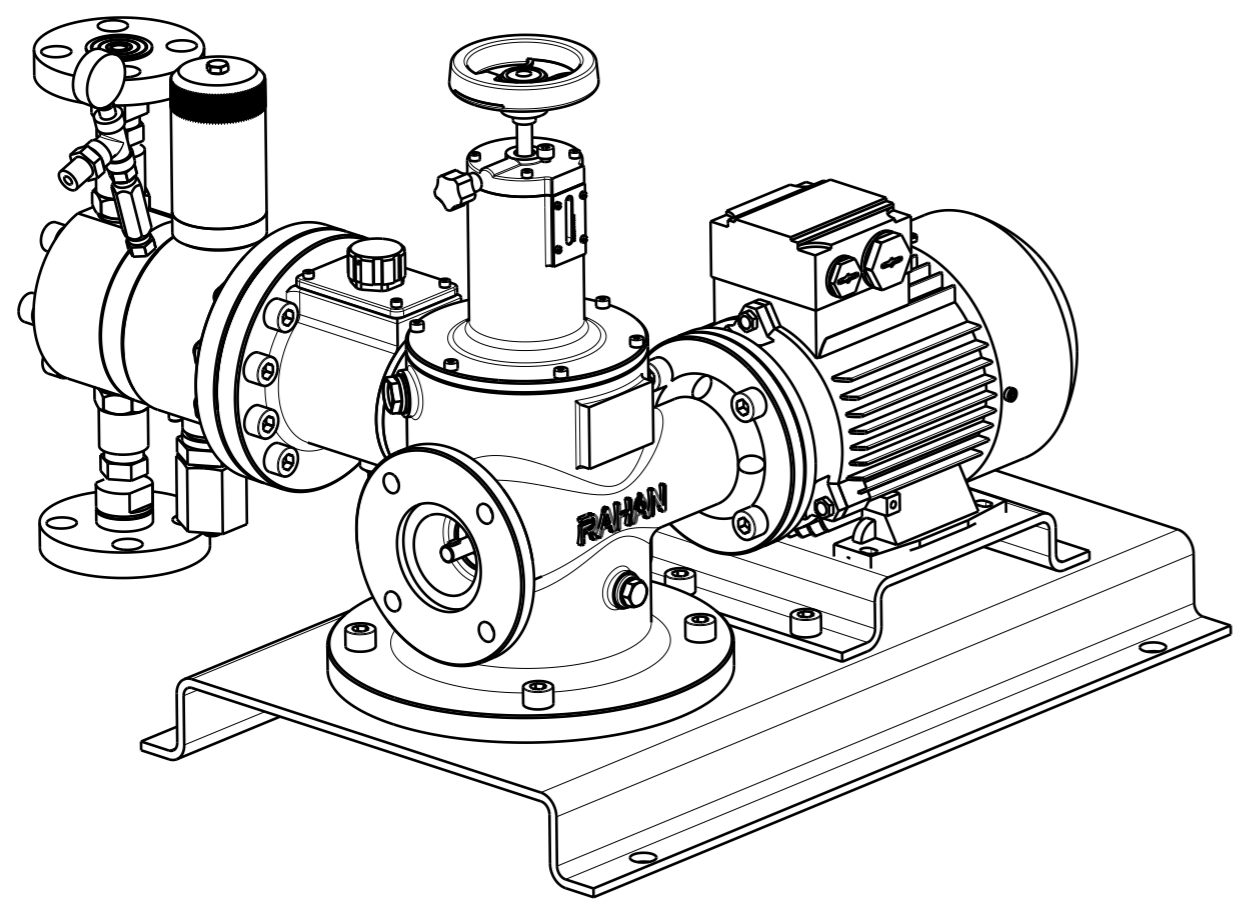

PUMP SIZE	L	W	H
DPG1P A	570	550	350
DPG1P B	700	850	450
DPG1P C	800	900	700
DPG1P D	1300	1000	1100
DPG1P E	2200	1900	1700

D

D

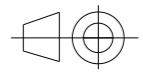
Service:CHEMICAL		Standard: API 675		ATEX COMPTIBILITY		RAPTURE DETECTOR		Pump Type:Positive Displacement Reciprocating Diaphragm Simplex		
Modify	Sign	Name	Date	Rev.	Date	Name	DWG No.: DPG1P-A1.GA-00			
					Design	1401/10/25	ME.Mirzabeigi	Material class: AS PER REQUEST		
					Check1	1401/10/25	G.Eslami	HYDRULIC ACTUATED		
					Check2	1401/10/25	R.Shokrollahi	HIGH PERSSION STROKE ADJUSTMENT		
				1	Approve	1401/10/25	A.Shoureshi	HIGH PRESSURE PERFORMANCE		
				2					DOUBLE DIAPHRAGM & DOUBLE CHECK VALVE ABILITY	
			3	Scale: 9:50					Sheet 1 of 1	Size: A2

1 2 3 4 5 6 7 8