

Sectional view
Scale: 1:5

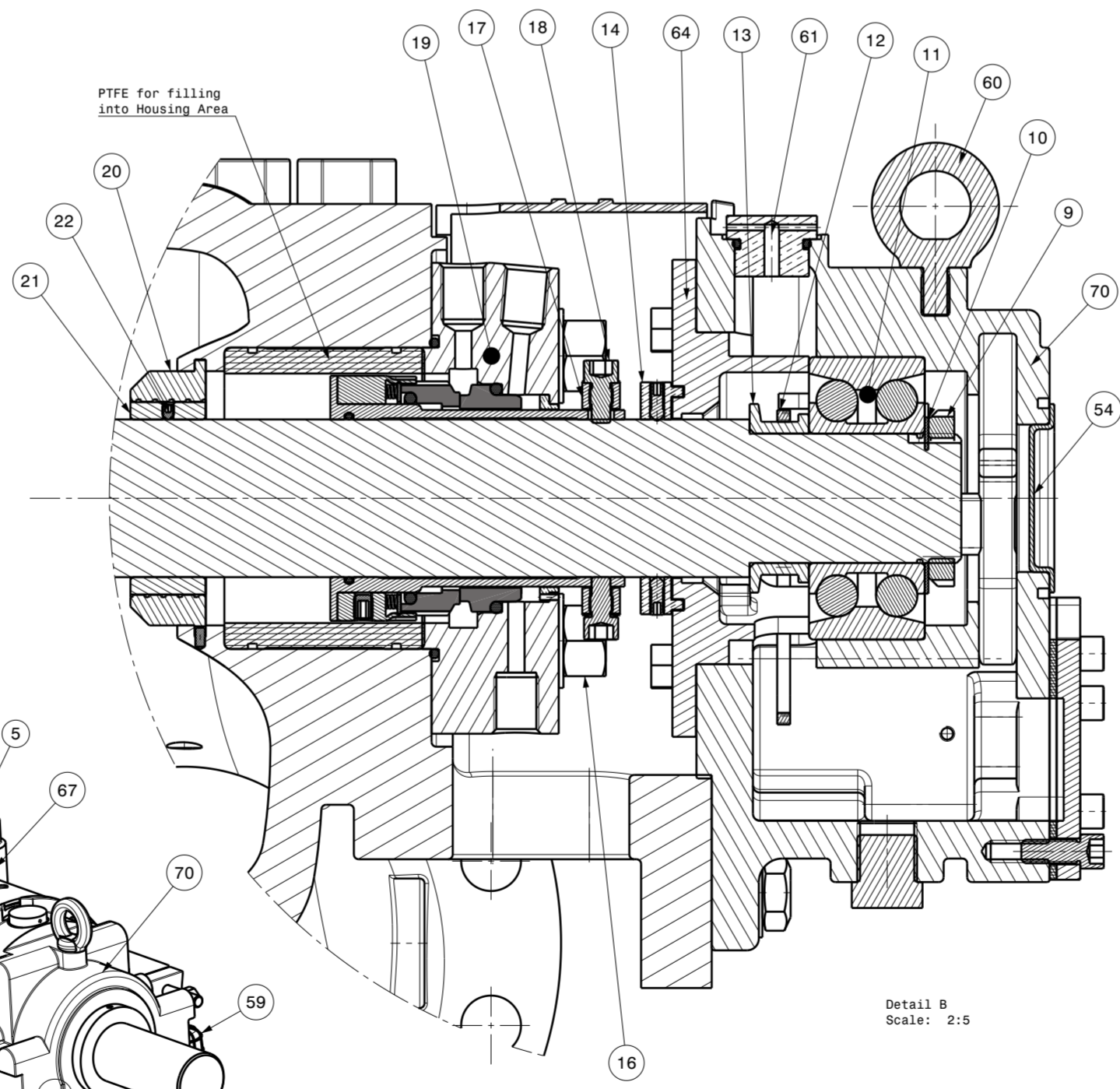

Detail B
Scale: 2:5

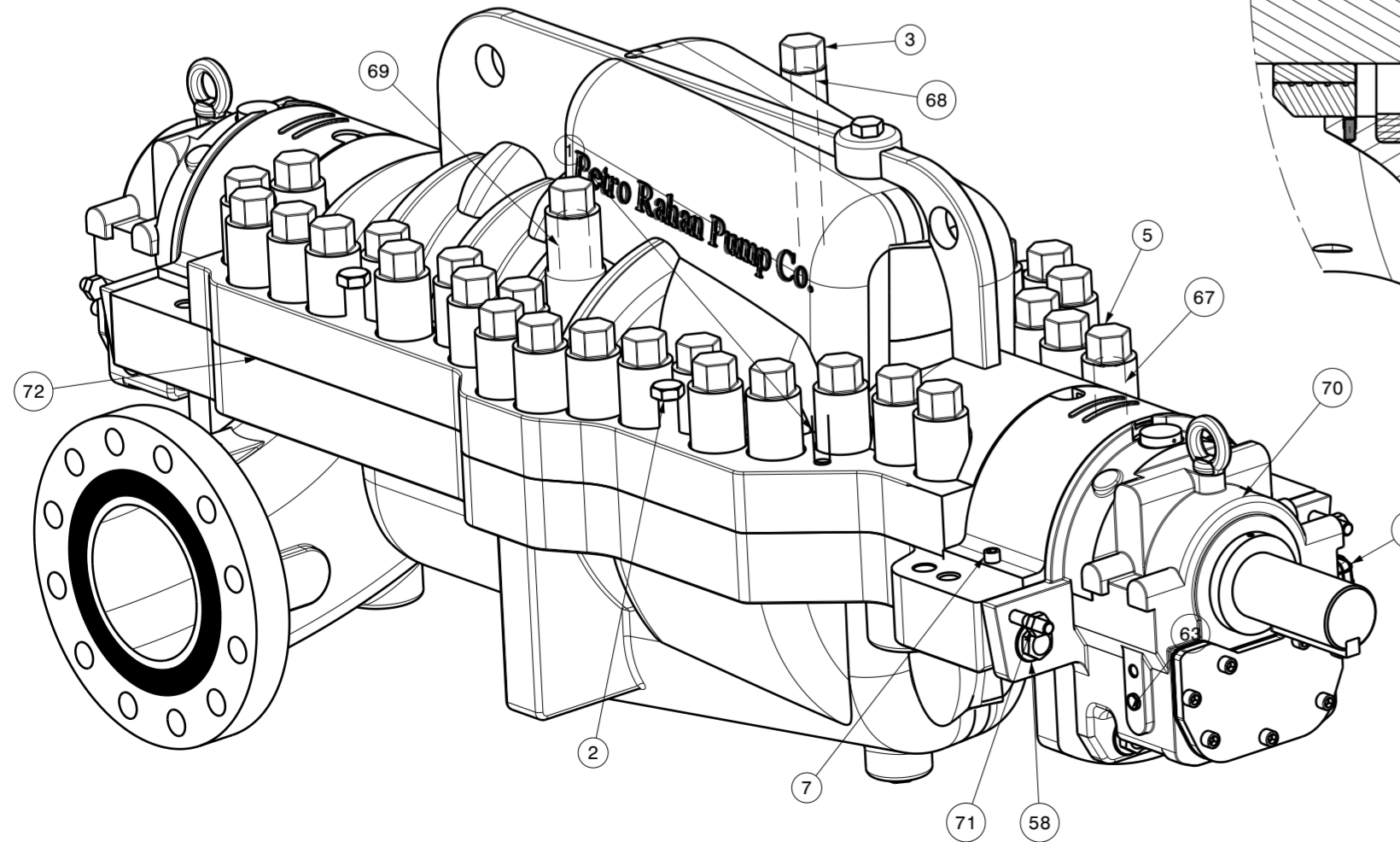

Item	Part Name	Part Code	Material	Description	Qty.
1	Pin-Guide Pin Casing	173E	St	Tapered 1/16	2
2	Jack Bolt-Casing	263P	St Gr 12.9	M18x100 Gr12.8	4
3	Cap Nut-Center	282P	St	M27x206	1
4	Cap Fitting(Plug-Casing)	241P	Standard (St)	3/4" NPT (API)	6
5	Cap Nut	281P	St	M32x86	39
6	Volute Case Top Half	179			1
7	Hexagon Socket Head Cap Screw	250P	St Gr 6.8	M10 , L=25	4
8	Gland Guard	203P	AL 7075		2
9	Locknut-Thrust bearing	110B	St	KM11 DIN 981 M55 x 2	1
10	Lock Washer-Thrust Bearing	132B	St	MB11 DIN 5406	1
11	Double Row Angular Contact Ball Bearing	106	SKF	Type 3311/C3	1
12	Oil Ring	126	C93500		2
13	Oil Ring Mounting Sleeve-Thrust Bearing	177B	Ck45		1
14	Deflector Disk-Inboard	140A	C93500		2
15	SET SCREW-Deflector		Ck45	M6x16	6
16	Stud Bolt-Gland	270P_0	AISI 304	M20 x Lt=110	8
17	Shaft Collar	45	Ck45		2
18	Hexagon Socket Head Cap Screw	48,52	St	M10 , L=18	12
19	Mechanical Seal Cartridge	8_00			2set
20	Throat Bushing	185			2
21	Bush Throat Bushing	185B			2
22	Set SCREW (Bush Trottle)		St	M5x6	6
23	Wear Ring-Case Stage_1	176A			1
24	Wear Ring-Impeller Stage_1	174A			1
25	Impeller Stage_1	113A			1
26	Wear Ring-Impeller Hub Series	174C			4
27	Stage Piece-Series	147A			4
28	Wear Ring-Case Series	176B			5
29	Wear Ring-Impeller Series	174B			5
30	Impeller Stage_2	113B			1
31	Impeller Stage_3	113C			1
32	Stage Piece-Centre	147B			1set
33	Thrust Ring	186			7
34	Key-Impeller	213A			4
35	Key-Shaft Sleeve Center	213C			1
36	Pump Shaft	123			1
37	Key-Coupling	213F			1
38	Pin-Throttle Bushing	173C		ø8 x 20	1
39	Key-Impeller St_4	213D			1
40	Pin-Centre Stage Piece	173B		ø10 x 20	1
41	Key-Impeller St_3	213B			1
42	Pin-Case Wear Rings	173A		ø4 x 10	11
43	Pin-Case Wear Ring Side	173A-P		ø4 x 8	1
44	Shaft Sleeve-Centre	171A			1
45	Impeller Stage_6	113F			1
46	Impeller Stage_5	113E			1
47	Impeller Stage_4	113D			1
48	Shaft Sleeve-Throttle	171B	GG25		1
49	Stage Piece-Side	147C-P	GG25		1
50	Oil Ring Mounting Sleeve-Radial Bearing	177A	Ck45		1
51	Single Row Deep Groove Ball Bearing	107	SKF	Type 6213/C3	1
52	Lock Washer-Radial Bearing	132A	St	MB13 DIN 5406	1
53	Locknut-Radial bearing	110A	St	KM13 DIN 981 M65 x 2	1
54	Bearing Cover-Outboard	164B	St		1
55	Cap Head Socket	250P	St Gr 8.8	M10	14
56	Bearing Housing End Cover	164C	GG20		2
57	Gasket-Bearing Housing End Cover	102C	NBR		2
58	Hexagon Head Bolt-Bearing Housing	260P-0	St Gr 10.8	M20	8
59	Oil Level Indicator		St	Standard	2
60	EyeBolt	245P	St	Standard M12 x 1.5	2
61	Air Vent Plug-Bearing	154_0	C93500	O-ring ø3.5 x 30	2
62	Plug-Bearing Housing	241P	St	3/4" NPT (API)	2
63	Sight Glass	240P	St	1/4" -NPT(API)	2
64	Bearing Cover-inboard	164A	Ck45		2
65	Hexagon Head Screw	262P	St Gr 8.8	M12 , L=25	12
66	Volute Case Bottom Half	114			1
67	Stud Bolt	271P	St Gr 12.8	M32 , Lt=150	39
68	Stud Bolt	273P	St Gr 12.8	M27 , Lt=190	1
69	Stud Bolt	272P	St Gr 12.8	M32 , L=230	1
70	Bearing Housing	163	GG25		2
71	Taper Guide Pin	300P	St Hardened	Tread=1/2"-13UNC 1/16	1
72	Gasket-Casing	102A			1
73	Deflector Disk-Outboard	140B	C93500		1

STANDARD: API610	SIDE-SIDE	ATEX	HYDRAULIC BALANCE	Type: Centrifugal Between Bearing Multistage Axially Split pump
Modify	Sign	Date	Rev.	Date
	-	-	1	1401/10/26
	-	-	2	1401/10/26
	-	-	3	1401/10/26
Name		Name		DWG No:BB3P.A1.SD-00
G.Eslami		ME.Mirzabeygi		Material Class: AS PER REQUEST
R.Shokrollahi		A.Shoureshi		HEATING JACKET OPTIONAL
				LOW VIBRATION OPERATION
				SERVICE: OIL & GAS
 www.petroarahanpump.ir		 Scale: 9:100		CONVENIENT MAINTENANCE
				Sheet 1 of 1
				Size: A3